

- 1
- 2
- 3
- 4
- 5
- 6
- 7
- 8
- 9
- 10
- 11
- 12
- 13
- 14
- 15
- 16
- 17
- 18

**MATERIAL**

Hardened AISI 431 stainless steel.

**FEATURES AND APPLICATIONS**

GN 412.5 bushings are a standard accessory to be used to create, when necessary, a matching part to the spring pistons.

Suitable for use on positioning flanges GN 412.1 (see page 781) and GN 612.1 (see page 780) with M12 and M16 threads.

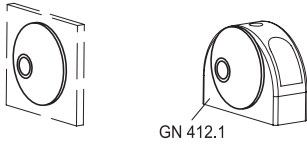

GN 412.1

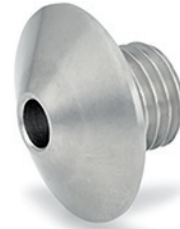

Application example

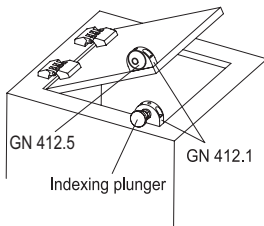

Conversion Table 1 mm = 0.039 inch	
d2	
mm	inch
4.2	0.17
5.2	0.20
6.2	0.24
8.2	0.32
10.2	0.40
12.2	0.48

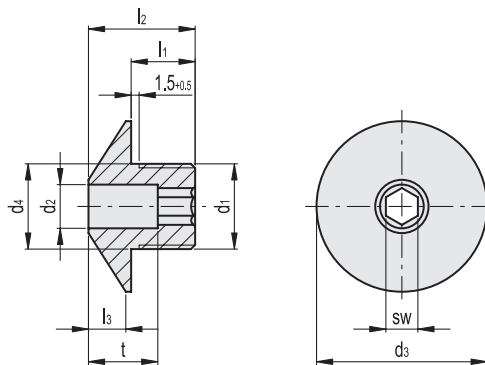

Code	Description	d1	d2 +0.1	d3	d4 -0.05	l1	l2	l3	sw	t	△
GN.18621	GN 412.5-M12x1.5-B4.2	M12x1.5	4.2	24	12	10	16	5	4	11	17
GN.18623	GN 412.5-M12x1.5-B5.2	M12x1.5	5.2	24	12	10	16	5	4	11	16
GN.18625	GN 412.5-M12x1.5-B6.2	M12x1.5	6.2	24	12	10	16	5	4	11	16
GN.18631	GN 412.5-M16x1.5-B8.2	M16x1.5	8.2	32	16	12	20	7	6	13	37
GN.18627	GN 412.5-M16x1.5-B10.2	M16x1.5	10.2	32	16	12	20	7	6	13	35
GN.18629	GN 412.5-M16x1.5-B12.2	M16x1.5	12.2	32	16	12	20	7	6	13	33